

# 代步车专用安全刹车器 ALS0S4AA

广州明协工业器材有限公司 ( 1 3 7 1 0 9 6 7 2 4 4 余先生 ) 是台湾仟岱有限公司在中国大陆的总代理。主要产品有电磁离合器、磁粉离合器、电磁刹车器等。品种齐全、质量可靠、供货稳定、价格最实惠！<http://www.chaintail.com.cn>

## 產品規格表 SPECIFICATIONS:

型號 Model	電壓D.C. Voltage	阻抗D.C. Resistance	功率 Power	絕緣等級 Insulation Classification	動摩擦轉距 Dynamic Friction Torque kgm(Nm)	靜摩擦轉距 Static Friction Torque kgm(Nm)	絕緣阻抗 Insulation Resistance	絕緣耐壓 Insulation Pressure Durability	作動電壓 Dynamic Voltage	間隙 (mm) Gap	重量 (kg) Weight
ALS0S4AA	24V	46Ω	12W	F	0.4(4.0)	0.45(4.5)	500VDC/50MΩ以上	1500V/1MA/1SEC	16V	0.13-0.18	0.42

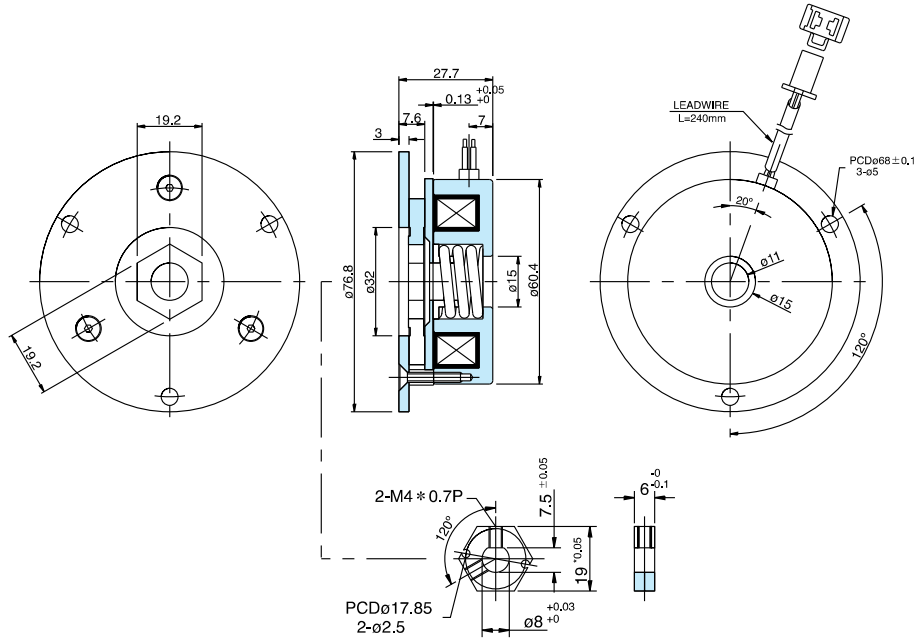

# ALY0S2AA

## 產品規格表 SPECIFICATIONS:

型號 Model	電壓D.C. Voltage	阻抗D.C. Resistance	功率 P	絕緣等級 Insulation Classification	動摩擦轉距 Dynamic Friction Torque kgm(Nm)	靜摩擦轉距 Static Friction Torque kgm(Nm)	絕緣阻抗 Insulation Resistance	絕緣耐壓 Insulation Pressure Durability	作動電壓 Dynamic Voltage	間隙 (mm) Gap	重量 (kg) Weight
ALY0S2AA	24V	65Ω	9W	F	0.17(1.7)	0.2(2.0)	500VDC/50MΩ以上	1500V/1MA/1SEC	16V	0.1-0.15	0.5

